

BoWex® AS und Spez.-I Bogenzahn-Kupplung®

Kompakt und wartungsfrei

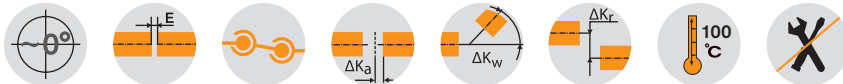

Bauteile

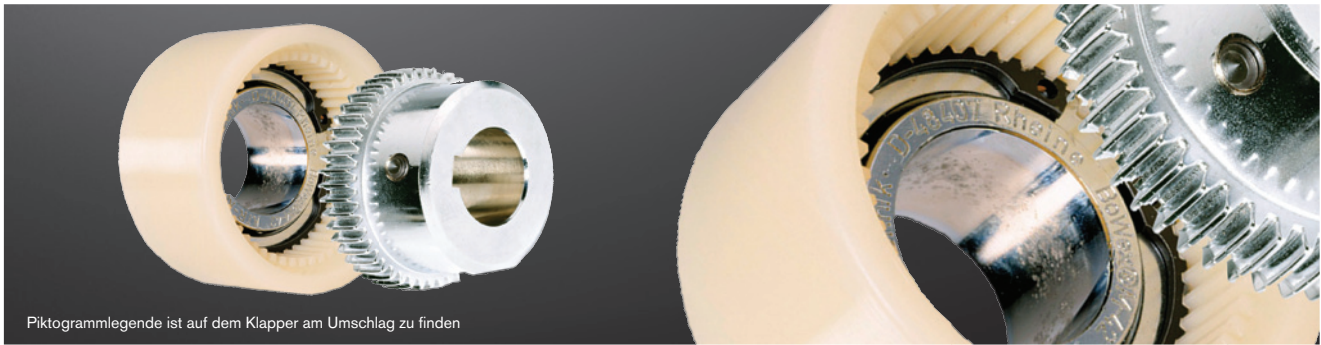
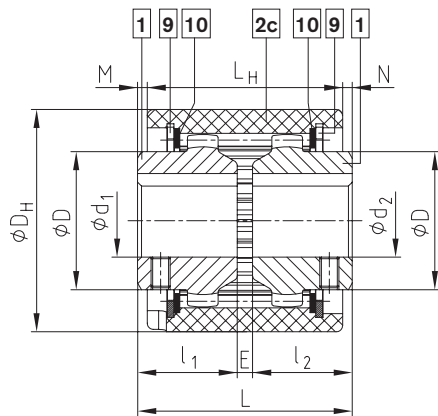

Bauart AS

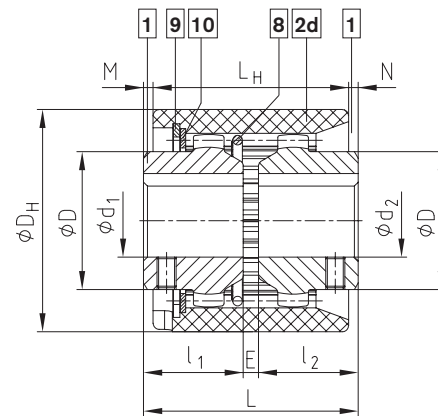

Bauart Spez. - I

BoWex® Bauart AS und Bauart Spez.-I																		
Größe	Vorbereitung		Fertigbohrung d ₁ , d ₂	Abmessungen [mm]								Gewicht bei max. Bohrungs-Ø			Massenträgheitsmoment J bei max. Bohrungs-Ø			
	ungebohrt	vorgebohrt		max.	l ₁ , l ₂	E	L	L _H	M, N	D	D _H	Nabe ver. l ₁ , l ₂ max.	Hülse [kg]	Nabe [kg]	Gesamt [kg]	Hülse [kgcm ²]	Nabe [kgcm ²]	Gesamt [kgcm ²]
24	x	-	Fertigbohrungen siehe Lagerprogramm	24	26	4	56	51	2,5	36	58	50	0,11	0,14	0,39	0,38	0,36	1,10
28	x	-		28	40	4	84	56	14	44	70	55	0,16	0,33	0,82	1,54	1,22	3,98
32	x	-		32	40	4	84	58	13	50	84	55	0,21	0,43	1,07	2,75	2,17	7,09
45	x	-		45	42	4	88	60	14	65	100	60	0,27	0,63	1,53	5,49	5,66	16,81
65	-	21		65	55	4	114	84	15	96	140	70	0,84	2,10	5,00	29,83	43,96	117,8
80	-	31		80	90	6	186	93	46,5	124	178	-	1,30	5,20	11,70	83,20	150,8	384,8
100	-	38		100	110	8	228	102	63	152	210	-	2,05	9,40	20,80	184,4	401,3	987,0
125	-	45	125	140	10	290	134	78	192	270	-	4,32	19,44	43,10	620,0	1362,3	3344,6	

Bestellbeispiel:	BoWex® 32 AS	d ₁ Ø32	d ₂ Ø32
	Kupplungsgröße und Bauart AS oder Spez.-I	Fertigbohrung H7 Nute DIN 6885 Bl. 1 (JS9)	Fertigbohrung H7 Nute DIN 6885 Bl. 1 (JS9)