

Variety of uses

Whichever transport purpose BRECO® and BRECOFLEX® timing belts are used for, the back of the belt can be fitted with any number and sequence of welded-on profiles.

The profiles consist of polyurethane, the same high-quality material as the timing belts themselves. A selection of profile shapes with standard dimensions is shown in this catalogue.

Other customer-specific profile shapes are also available. Within our production capabilities, the profile shape for transported goods and transportation purposes can be freely determined according to the customer's requirements. The injection moulds are manufactured in our own tool building facilities. This ensures fast availability.

Please observe the design guidelines on the following pages.



Rotary indexing magazine



Supply belt



Synchronous conveyor

Construction features

At first, the basis for the selection of belt type, belt length and the depending pulleys is the surrounding construction. All belt types of our manufacturing range can be equipped with flights/profiles. Timing belts together with bed plates enable a reduced friction transportation. BRECO® and BRECOFLEX® timing belts in the version PAZ are alternatively available.

Profile selection

The material to be transported and the transport purpose influence the selection of the flight. Following possibilities of flight versions are available:

- Profiles of existing standard tools
Profiles are manufactured as polyurethane moulded part
Over 2500 standard profiles are available. Depending on their dimensions, standard profiles can be reworked by mechanical processes (drilling, milling). If necessary, explain design requirements by means of a drawing.
- Profiles of sheet material
Depending on the quantity, flights will possibly be cut from pre-fabricated PUR sheets. The following board thicknesses are available:
1,5; 2; 3; 4; 5; 6; 7; 8; 10; 11; 15; 20 mm
- Profiles of new tool
Within the framework of our production possibilities, there are practically no limitations for new design requirements as far as the shape of injection moulded flights are concerned. Costs for tools and moulds might apply.

Profile position opposite tooth

The belt flexibility of timing belts is located mainly in the tooth gap area. To retain the timing belt flexibility around the pulley, the profile position „opposite the tooth“ is to be preferred.

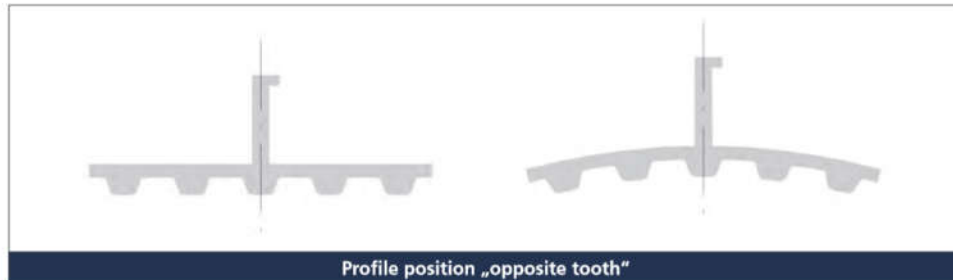

Profile pitch Tooth pitch

We recommend to select a Profile pitch which is an integral multiple of that of the tooth. Profile pitches other than the integral multiple of the tooth pitch can be supplied, it has, however, to be noted, that a uniform offset of the profile position in relation to the tooth position will accumulate.

Tolerances

The reached profile position of each individual profile is ± 0.5 mm of the intended set point position. A tolerance of ± 0.5 mm is to be taken into account for the profile height.

Ordering example:

Construction features

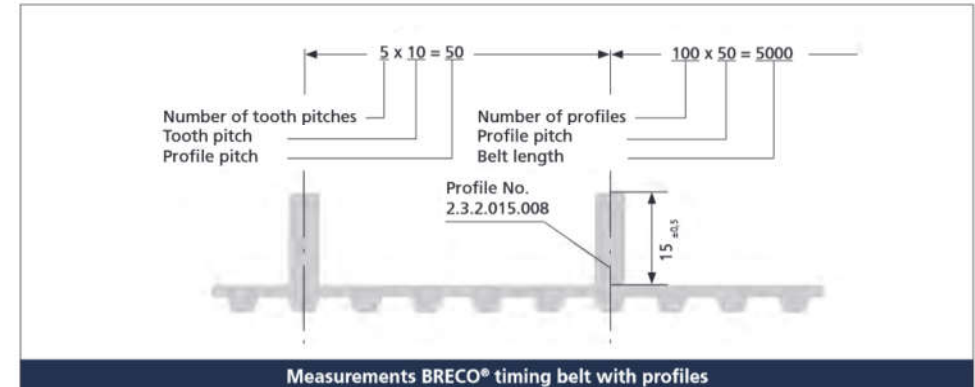

The equipping of the timing belt with profiles is always made as a multiple of the tooth pitch, i.e. the welded on flight position follows exactly the belt tooth pitch. For this reason, a cumulative error from profile pitch to tooth pitch will not occur.

For the required timing belt with profiles the order should preferably be accompanied by a dimensional drawing. The timing belt with profiles can also be defined and transmitted by the order text.

Example: BRECO® timing belt 50 T 10/5000 V-PAZ with welded-on profiles
Profile no. 2.3.2.015.008,
Number of profiles 100,
Profile pitch 50,
Profile position opposite the tooth.

Joined version

Joining is made by welding the full profile fitting surface on the back of the belt.

Flash

A flash builds up between flight and back of the belt. A polyurethane overhang with a 0.5 to 1 mm radius could form. Should the flash impair the intended function, ask for „flash removed“ in your order information.



Construction features

Profile thickness s

The timing belt flexibility can be influenced by the welded-on flight. Note as a rule that the flight thickness s is to be selected as thin as possible. The table below shows the individually recommended maximum profile thickness s in mm in relation to the selected number of pulley teeth.

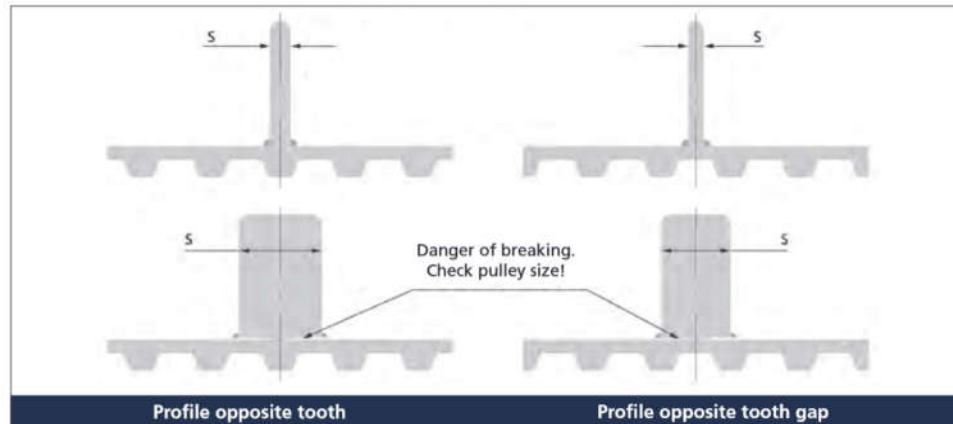

Max. thickness s [mm]

Type / pitch	Max. profile thickness in mm when welded on position is opposite tooth													
	Max. profile thickness in mm when welded on position is opposite tooth gap													
	Number of pulley teeth													
	20		25		30		40		50		60		100	
T2,5	2,5	1,5	3	1,5	3	2	4	2	4,5	3	5	4	6	6
T5	5	2	6	2	6	3	8	4	9	6	10	8	12	10
T10	8	3	9	4	10	4	12	6	14	9	15	12	20	20
T20	12	5	13	5	15	6	18	8	20	12	23	20	30	30
AT3	3	1,5	4	1,5	4	2	5	3	6	4	6,5	5	8	7
AT5	5	2	6	2	6	3	8	4	9	6	10	8	12	10
AT10	8	3	9	4	10	4	12	6	14	9	15	12	20	20
AT20	12	5	13	5	15	6	18	8	20	12	23	20	30	30
MXL	2	1	2,5	1	2,5	1,5	3,5	1,5	4	2	4,5	3	5	5
XL	5	2	6	2	6	3	8	4	9	6	10	8	12	10
L	6	3	7	3	8	4	10	5	12	7	13	10	16	16
H	8	4	9	5	10	6	12	7	14	10	15	12	20	20
XH	13	5	14	5	15	6	18	8	20	12	23	20	30	30

Example for the calculation of the profile thickness s for a BRECO® timing belt with pitch T10, which is running around a pulley with 20 teeth:

- When the profile position is „opposite the tooth“, profile thickness $s \leq 8$ mm,
- When the profile position is „opposite the tooth gap“, profile thickness $s \leq 3$ mm.

Remark:

We recommend to select the next smaller size as profile thickness when there are intermediate sizes (e.g. 22 teeth).

Construction features

Profiles with undercut

The timing belt flexibility is assured, when there are planned corresponding undercuts.

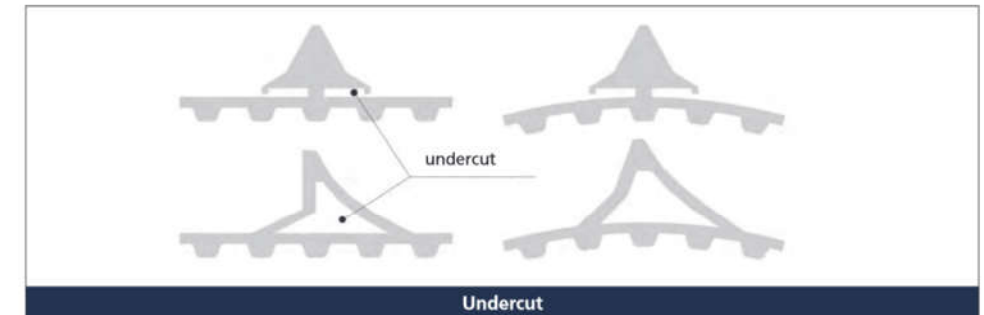

Profile pair

Profile pairs (profile chambers, profile pockets) are preferred in the transport technology for parts positioning and for so-called inset procedures. For the clearance between the profiles, the production tolerance amounts to ± 0.5 mm. Indicate a tolerance reduced to ± 0.2 mm separately, while taking make-ready and/or tool costs into consideration.

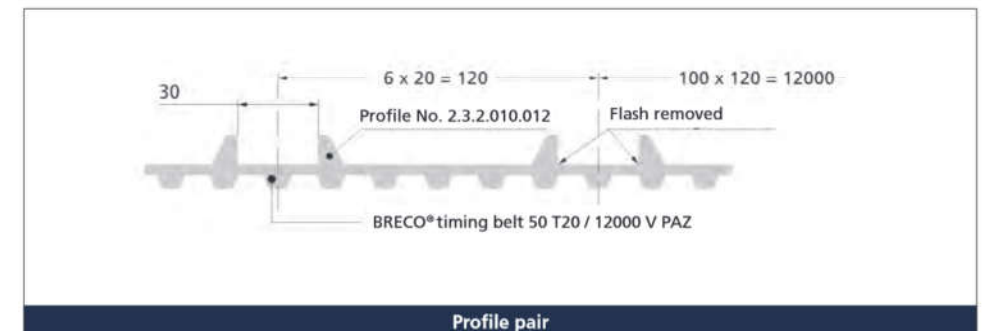

Construction features

Profiles with moulded inserts

Profiles with moulded inserts can be manufactured for special functional characteristics. To shape moulded inserts (steel, aluminium or similar) please ensure the existence of appropriate undercuts.

Remark: The orderer has to make available a sufficient number of moulded-in inserts with an approx. 5 % surplus for the manufacture of samples.

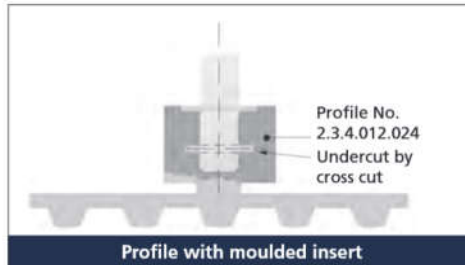

Profile with moulded insert

Profiles with bore holes

It is possible to ask for boreholes for special profile attachments. Tolerances are to be considered.

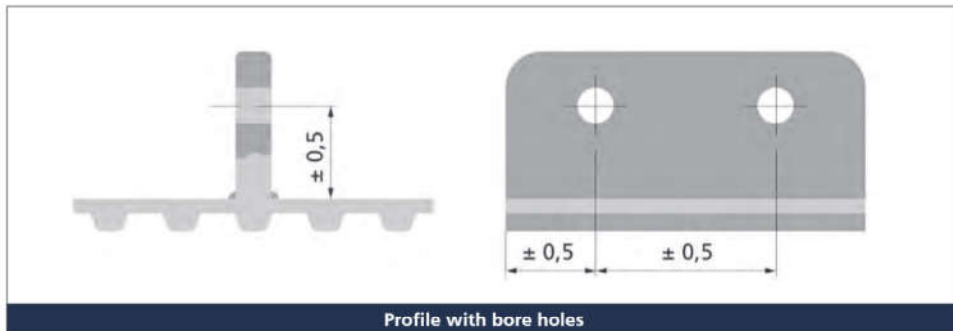

Profile with bore holes

Selection of standard profiles

These profiles for welding on only represent a small selection from our entire range. Over 2700 existing profile shapes are available. These profile shapes can be adapted to special requirements by mechanical processing in smaller series.

Our sales partners will gladly help you find solutions for certain transport tasks.



Profile no. 2.3.5.663



Profile no. 2.3.6.936



Profile no. 2.3.4.012.024



Profile no. 2.3.5.708



Profile no. 2.3.7.446



Profile no. 2.3.5.678

Selection of standard profiles

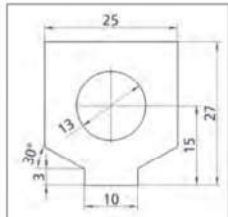

Depth: 50 mm
Profile No. 2.3.3.025.027

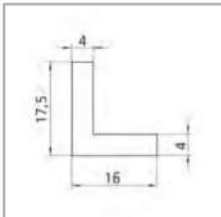

Depth: 48 mm
Profile No. 2.3.3.017.016

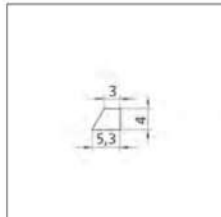

Depth: 25 mm
Profile No. 2.3.3.004.005

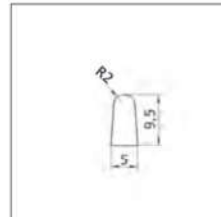

Depth: free
Profile No. 2.3.3.009.005

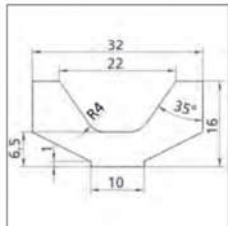

Depth: 15 mm
Profile No. 2.3.3.016.032

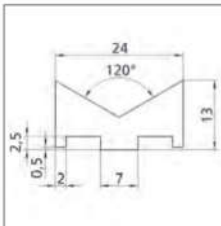

Depth: 15 mm
Profile No. 2.3.3.013.024

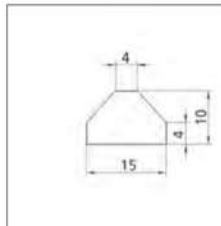

Depth: 35 mm
Profile No. 2.3.3.015.010

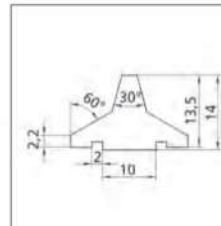

Depth: 170 mm
Profile No. 2.3.3.014.022



Depth: 15 mm
Profile No. 2.3.3.016.020

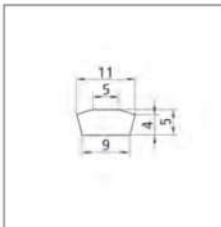

Depth: 25.4 mm
Profile No. 2.3.3.011.005

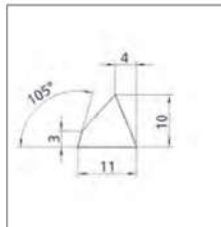

Depth: 98 mm
Profile No. 2.3.3.011.010

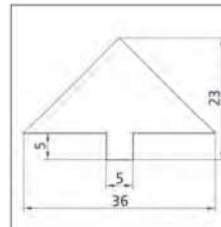

Depth: 100 mm
Profile No. 2.3.3.023.036

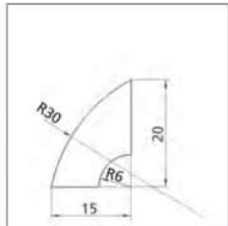

Depth: 100 mm
Profile No. 2.3.3.020.015

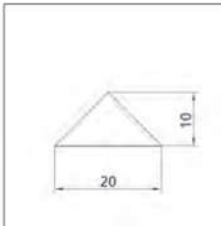

Depth: 100 mm
Profile No. 2.3.3.020.010

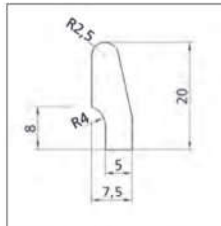

Depth: 70 mm
Profile No. 2.3.3.007.020

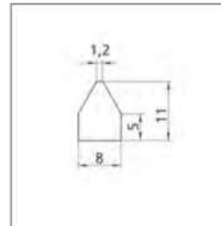

Depth: 10 mm
Profile No. 2.3.3.008.011

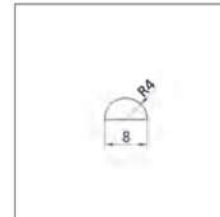

Depth: 100 mm
Profile No. 2.3.1.008.004

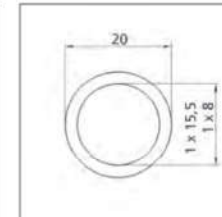

Depth: 50 mm
Profile No. 2.3.1.015.020

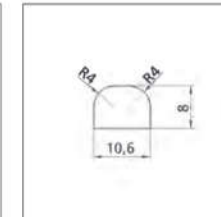

Depth: 100 mm
Profile No. 2.3.2.008.010

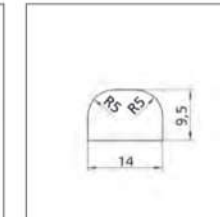

Depth: 64 and 100 mm
Profile No. 2.3.2.009.014

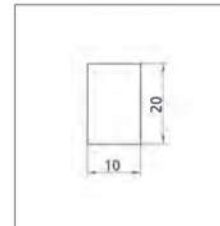

Depth: 100 mm
Profile No. 2.3.2.010.020

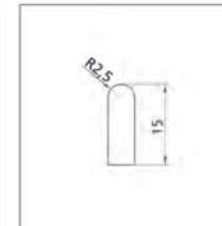

Depth: 195 mm
Profile No. 2.3.2.015.005

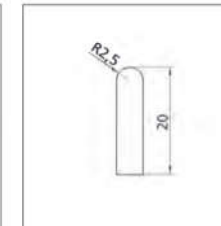

Depth: 100 mm
Profile No. 2.3.2.020.005

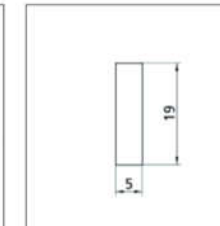

Depth: 64 mm
Profile No. 2.3.2.019.005

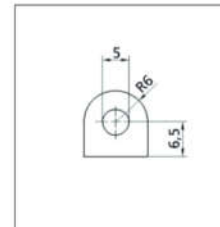

Depth: 50 mm
Profile No. 2.3.2.012.012

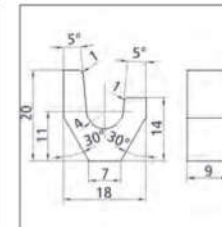

Profile No. 2.3.2.018.020

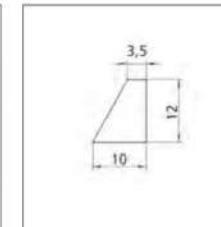

Depth: 130 mm
Profile No. 2.3.2.010.012

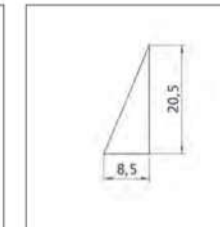

Depth: 100 mm
Profile No. 2.3.2.008.020

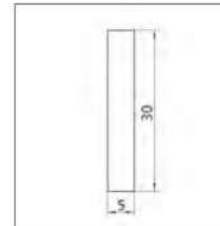

Depth: 100 mm
Profile No. 2.3.2.030.005

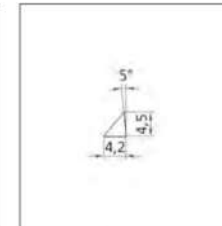

Depth: 101.6 mm
Profile No. 2.3.2.004.004

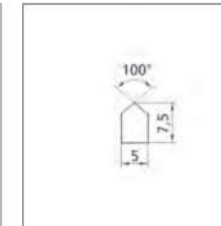

Depth: 100 mm
Profile No. 2.3.2.005.007

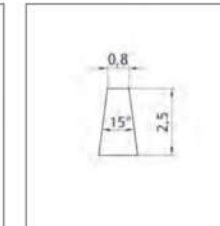

Depth: 64 mm
Profile No. 2.3.2.001.002