

POLY-NORM® BTA und SBA elastische Kupplungen

Mit Bremsstrommel/Bremsscheibe für Haltebremse

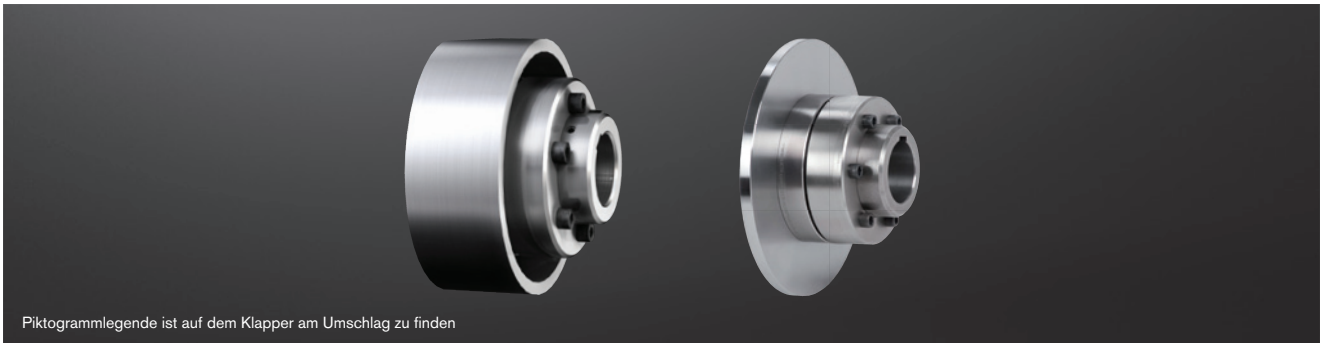

Piktogrammlegende ist auf dem Klapper am Umschlag zu finden

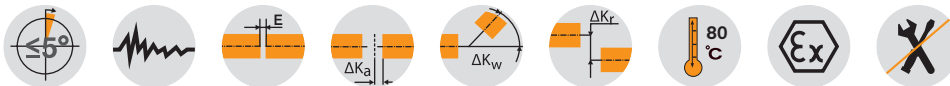

Bauteile

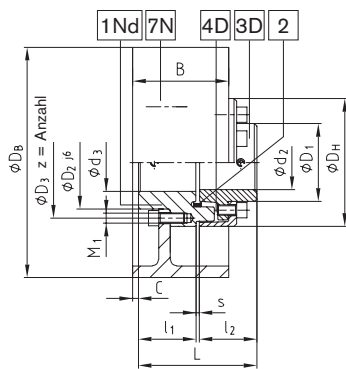

Bremstrommel Bauart ADR-BTA

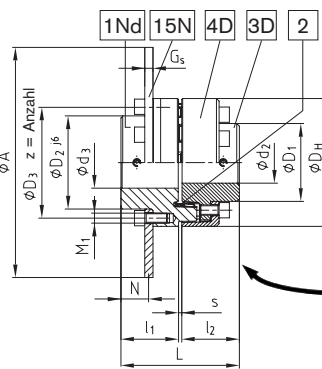

Bremsscheibe Bauart ADR-SBA

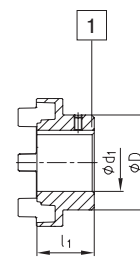

Flanschnabe 3D+4D durch Standard Nabe 1 austauschbar

Mit Standard Nabe
Bauart AR-BTA oder AR-SBA

POLY-NORM® Bauart AR-BTA, AR-SBA, ADR-BTA und ADR-SBA

Größe	Elastomerring Drehmoment [Nm] ¹⁾		Abmessungen [mm]											
	TKN	TKmax.	D; D ₁	max. Fertigbohrung			D _H	D ₂	D ₃	z	M ₁	l ₁ ; l ₂	s	L
				d ₁	d ₂	d ₃								
38	90	180	Maß ØD, ØD ₁ finden Sie in unserem Gesamtkatalog Seite 64 und 65	40	34	38	87	61	75	5 x 72°	M6	38	4	80
42	150	300		45	38	42	96	68	82	5 x 72°	M8	42	4	90
48	220	440		50	44	48	106	77	92	6 x 60°	M8	48	5	101
55	300	600		60	50	55	118	88	104	6 x 60°	M8	55	5	115
60	410	820		65	56	60	129	96	114	6 x 60°	M8	60	5	125
65	550	1100		70	60	65	140	104	122	6 x 60°	M10	65	5	135
75	850	1700		80	68	75	158	121	140	6 x 60°	M10	75	5	155
85	1350	2700		90	78	85	182	137	160	6 x 60°	M12	85	5	175
90	2000	4000		95	85	90	200	146	174	6 x 60°	M16	90	5	185
100	2900	5800		110	95	100	224	164	195	6 x 60°	M16	100	6	206
110	3900	7800		50-120	105	50-110	250	184	218	8 x 45°	M16	110	6	226
125	5500	11000		55-140	115	55-125	280	208	245	8 x 45°	M20	125	6	256
140	7200	14400		65-155	55-135	65-140	315	233	276	8 x 45°	M20	140	6	286
160	10000	20000		75-175	65-155	75-160	350	263	308	9 x 40°	M20	160	6	326
180	13400	26800		75-200	65-175	75-180	400	298	349	10 x 36°	M20	180	6	366

POLY-NORM® Bauart BTA																	POLY-NORM® Bauart SBA																				
POLY-NORM® Größe ØD _B xB Bremsstrommel ²⁾	38	42	48	55	60	65	75	85	90	100	110	125	140	160	180	Drehzahl 1/min bei v=60 m/s ³⁾	POLY-NORM® Größe ØA x G Brems-scheibe ²⁾	38	42	48	55	60	65	75	85	90	100	110	125	140	160	180	Drehzahl 1/min bei v=60 m/s ³⁾				
	Abmessungen [mm] C																	Abmessungen [mm] N																			
160x60	4															7150	200x12,5	13,75													5725						
200x75	9	8	4													5725	250x12,5	13,75	14,75	18,75											4575						
250x95	17	16	20	7	3	0										4575	315x16		13	17	22	26	29	35,5							3625						
315x118		25	21	16	12	9	2,5	-3,5								3625	400x16			17	22	26	29	35,5	41,5	42	48				2850						
400x150			34	28	25	22	15,5	9,5	9	3						2850	500x16				22	26	29	35,5	41,5	42	48	54	64		2275						
500x190										18	12	-2				2275	630x20										46	52	62	69	86		1800				
630x236											20	13	-4			1800	710x20										46	52	62	69	86	104	1600				
710x265												24	7	-11		1600	800x25														43,5	49,5	59,5	66,5	83,5	101,5	1425
																																49,5	59,5	66,5	83,5	101,5	1250

¹⁾ Standard-Werkstoff Perbunan [NBR], Auslegung Seite 10 ff.

²⁾ Stahl ³⁾ Dynamisch Wuchten erforderlich

Weitere Größen auf Anfrage

Bestell- beispiel:	POLY-NORM® 38	ADR-BTA	Ø200 x 75	d ₂ =Ø32 NnD	d ₃ =Ø25 NnD
	Kupplungsgröße	Bauart	Bremstrommel -Ø	Bauteil mit Fertigbohrung	Bauteil mit Fertigbohrung