

PRODUCT DESCRIPTION

optibelt VB CLASSIC V-BELTS

DIN 2215 / ISO 4184



Structure/Properties

optibelt VB classic V-belts are manufactured using the same production processes as those for optibelt SK high performance wedge belts.

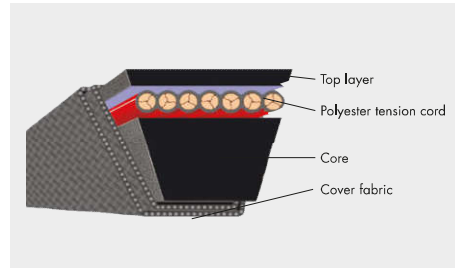

The components used are perfectly suited to the power ratings P_N . These values are far above those given by DIN 2218. Thus the operational safety in existing drives is increased and overloading is avoided.

- optibelt VB classic V-belts have a height-width ratio of 1:1.6.
- The maximum belt speed $v_{max} = 30$ m/s should not be exceeded.
- The allowed flexibility rate is far below that of wedge belts. It is $f_{B,max} = 80$ s⁻¹.

Application areas

optibelt VB classic V-belts are mainly employed as replacement parts for industrial drives. For new drives, the use of high performance wedge belts is almost always recommended due to reasons of space and cost. However, special drives such as V-flat drives can often only be operated with classic V-belts. In special constructions, optibelt VB classic V-belts tackle difficult drives in the gardening sector and in agricultural machinery.

For these applications special belt constructions and calculation methods are required which are not included in this manual. In these cases we ask you to give us the according drive data.

Standardisation/Dimensions

optibelt VB classic V-belts in the profiles Y/6, Z/10, A/13, B/17, C/22, D/32 and E/40 are standardised according to DIN 2215 and ISO 4184. Further, non-standardised ISO profiles 5, 8, 20 and 25 are available. These profiles should however not be used due to reasons of exchangeability and rationalisation.

The ISO standard 4184 specifies the datum length for measuring the belt length. The former belt designation of the inside length L_i is replaced by the datum length L_d . For the conversion factors from pitch to inside length, please see page 169.

Note: Electrically conductive according to ISO 1813.

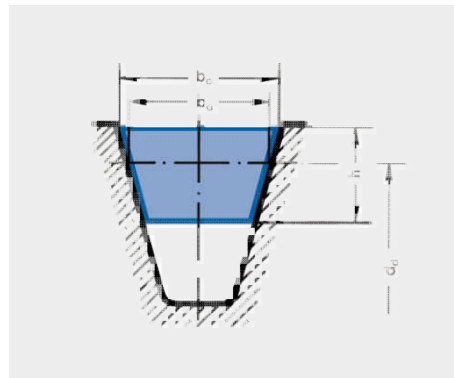

Table 7

Profile	DIN 2215	(5)	6	(8)	10	13	17	(20)	22	(25)	32	40
	ISO 4184	-	Y	-	Z	A	B	-	C	-	D	E
Belt top width	b_o	≈ 5	6	8	10	13	17	20	22	25	32	40
Datum width	b_d	4.2	5.3	6.7	8.5	11	14	17	19	21	27	32
Belt height	h	≈ 3	4	5	6	8	11	12.5	14	16	20	25
Recommended minimum pulley datum diameter	$d_{d,min}$	20	28	40	50	71	112	160	200	250	355	500
Belt weight (kg/m)		≈ 0.018	0.026	0.042	0.064	0.109	0.190	0.266	0.324	0.420	0.690	0.958
Flex rate (s ⁻¹)	$f_{B,max}$	≈						80				
Belt speed (m/s)	v_{max}	≈						30				

PRODUCT DESCRIPTION

optibelt KB KRAFTBANDS



Product characteristics

optibelt KB kraftbands are characterised by the following properties:

- High level of uniform power transmission
- Favourable running behaviour especially regarding vibration
- Excellent flexibility
- High centre distances with small pulley datum diameters
- V-flat drives
- Vertical drives
- Clutched drives and conveyance drives

Standardisation/Dimensions

optibelt KB wedge belts

optibelt KB kraftbands with high power wedge belts are manufactured in SPZ, SPA, SPB, SPC profiles as well as in 3V/9J, 5V/15J, 8V/25J in compliance with international conventions.

SPZ, SPA, SPB and SPC kraftbands can be used with V-grooved pulleys according to DIN 2211 and ISO 4183. 3V/9J, 5V/15J, 8V/25J kraftbands can be used with V-grooved pulleys according to ISO 5290 and ARPM/MPTA IP 22.

optibelt KB classic V-belts

optibelt KB kraftbands with classic V-belts are manufactured in AJ/HA, BJ/HB, CJ/HC, DJ/HD profiles in compliance with international conventions.

The ISO 5291 standard and the ARPM/MPTA IP 20 standard are applied to kraftbands in machine construction. The ASAE S211. ... USA standard is applied to kraftbands used in agricultural machine construction.

Note: Electrically conductive according to ISO 1813.

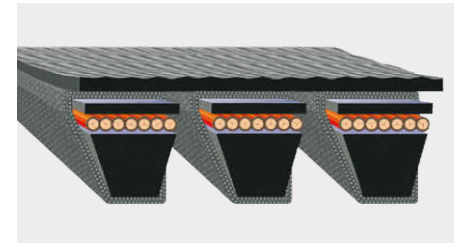

optibelt KB kraftbands consist of individual V-belts that are connected to one another via a top surface. Depending on the application the kraftbands will be fitted with two, three, four or five ribs.

On special request, kraftbands can also be delivered with more than five ribs.

When using multiple kraftbands per drive, combinations of sets are required.

Order example

The drive is to be equipped with a 5V 1600/15J 4064 kraftband with 18 ribs.

Kraftbands: Installation combination with 5/4/4/5 ribs

The order is as follows:

A KB set, consisting of:
 2 pieces optibelt KB kraftbands 4-5V 1600/15J 4064 and
 2 pieces optibelt KB kraftbands 5-5V 1600/15J 4064
 4 or 5 = quantity of ribs
 5V/15J = profile
 1600 = belt number or 160 inch belt length
 4064 = outside length in mm

STANDARD RANGE

optibelt **SK** HIGH PERFORMANCE WEDGE BELTS

ARPM/MPA

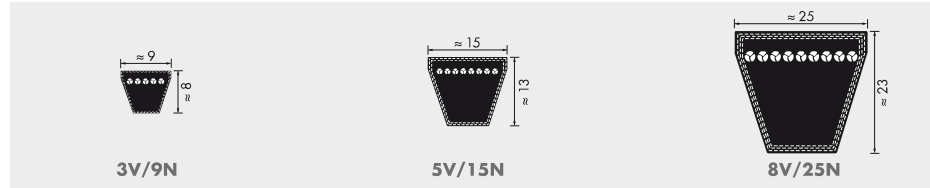

Profile 3V/9N		Profile 5V/15N		Profile 8V/25N	
Belt designation		Belt designation		Belt designation	
Profile, length code	Profile, outside length, L _d [mm]	Profile, length code	Profile, outside length, L _d [mm]	Profile, length code	Profile, outside length, L _d [mm]
3V 250	9N 635	5V 530	15N 1346	8V 1000	25N 2540
3V 265	9N 673	5V 560	15N 1422	8V 1120	25N 2845
3V 280	9N 711	5V 600	15N 1524	8V 1180	25N 2997
3V 300	9N 762	5V 630	15N 1600	8V 1250	25N 3175
3V 315	9N 800	5V 670	15N 1702	8V 1320	25N 3353
3V 335	9N 851	5V 710	15N 1803	8V 1400	25N 3556
3V 355	9N 902	5V 750	15N 1905	8V 1500	25N 3810
3V 375	9N 952	5V 800	15N 2032	8V 1600	25N 4064
3V 400	9N 1016	5V 850	15N 2159	8V 1700	25N 4318
3V 425	9N 1079	5V 900	15N 2286	8V 1800	25N 4572
3V 450	9N 1143	5V 950	15N 2413	8V 1900	25N 4826
3V 475	9N 1206	5V 1000	15N 2540	8V 2000	25N 5080
3V 500	9N 1270	5V 1060	15N 2692	8V 2120	25N 5385
3V 530	9N 1346	5V 1120	15N 2845	8V 2240	25N 5690
3V 560	9N 1422	5V 1180	15N 2997	8V 2360	25N 5994
3V 600	9N 1524	5V 1250	15N 3175	8V 2500	25N 6350
3V 630	9N 1600	5V 1320	15N 3353	8V 2650	25N 6731
3V 670	9N 1702	5V 1400	15N 3556	8V 2800	25N 7112
3V 710	9N 1803	5V 1500	15N 3810	8V 3000	25N 7620
3V 750	9N 1905	5V 1600	15N 4064	8V 3150	25N 8001
3V 800	9N 2032	5V 1700	15N 4318	8V 3350	25N 8509
3V 850	9N 2159	5V 1800	15N 4572	8V 3550	25N 9017
3V 900	9N 2286	5V 1900	15N 4826	8V 3750	25N 9525
3V 950	9N 2413	5V 2000	15N 5080	8V 4000	25N 10160
3V 1000	9N 2540	5V 2120	15N 5385	8V 4250	25N 10795
3V 1060	9N 2692	5V 2240	15N 5690	8V 4500	25N 11430
3V 1120	9N 2845	5V 2360	15N 5994	8V 4750	25N 12065
3V 1180	9N 2997	5V 2500	15N 6350	8V 5000	25N 12700
3V 1250	9N 3175	5V 2650	15N 6731		
3V 1320	9N 3353	5V 2800	15N 7112		
3V 1400	9N 3556	5V 3000	15N 7620		
		5V 3150	15N 8001		
		5V 3350	15N 8509		
		5V 3550	15N 9017		

Maximum production length: 4500 mm L_d
Minimum order quantity:
Over 1800 mm L_d =
20 pieces for non-standard length ranges
60 pieces for special constructions

Weight: ≈ 0.074 kg/m

Maximum production length: 18000 mm L_d
Minimum order quantity:
Over 1800 mm L_d =
25 pieces for non-standard length ranges
75 pieces for special constructions

Weight: ≈ 0.195 kg/m

Maximum standard production length:
21000 mm L_d
Over 18000 to 21000 mm on request
Minimum order quantity:
Over 2540 mm L_d =
11 pieces for non-standard length ranges
33 pieces for special constructions

Weight: ≈ 0.575 kg/m

STANDARD RANGE

optibelt **VB** CLASSIC V-BELTS

DIN 2215 / ISO 4184

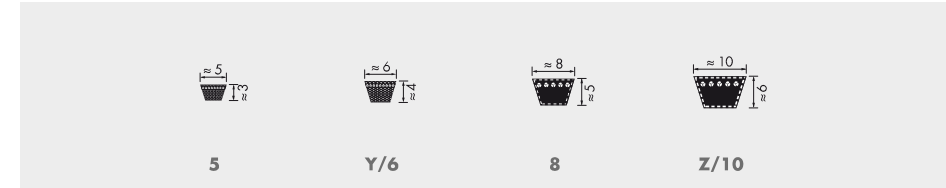

Profile 5*		Profile Y/6*		Profile 8		Profile Z/10								
Datum length ISO L _d [mm]	Inside length L _i [mm]	Datum length ISO L _d [mm]	Inside length L _i [mm]	Datum length ISO L _d [mm]	Inside length L _i [mm]	Belt no.	Datum length ISO L _d [mm]	Inside length L _i [mm]	Belt no.	Datum length ISO L _d [mm]	Inside length L _i [mm]	Belt no.	Datum length ISO L _d [mm]	Inside length L _i [mm]
200	190	295	280	335*	315*	Z 11	312*	290*	Z 38 1/2	997	975	Z 68	1747	1725
239	229	315	300	375*	355*	Z 12 1/2	337*	315*	Z 39	1022	1000	Z 69	1772	1750
270	260	350	335	420*	400*	Z 14	397*	375*	Z 40	1038	1016	Z 70	1797	1775
290	280	415	400	445*	425*	Z 15	422*	400*	Z 40 1/2	1052	1030	Z 71	1822	1800
310	300	440	425	470*	450*	Z 16	447*	425*	Z 41	1063	1041	Z 73	1872	1850
325	315	465	450	495*	475*	Z 17	472*	450*	Z 41 1/2	1072	1050	Z 75	1922	1900
332	322	515	500	510*	490*	Z 18	497*	475*	Z 42	1082	1060	Z 78	1997	1975
345	335	555	540	550*	530*	Z 19	502*	480*	Z 43	1102	1080	Z 79	2022	2000
385	375	615	600	580*	560*	Z 19 1/4	522*	500*	Z 43 1/4	1122	1100	Z 83 1/2	2142	2120
435	425	865	850	595*	575*	Z 20	537*	515*	Z 44	1142	1120	Z 88	2262	2240
485	475			620*	600*	Z 20 1/2	547*	525*	Z 45	1172	1150	Z 93	2382	2360
510	500			650*	630*	Z 21	552*	530*	Z 46	1187	1165	Z 98	2522	2500
540	530			690*	670*	Z 21 1/4	562*	540*	Z 46 1/2	1202	1180			
564	554			720*	700*	Z 22	582*	560*	Z 47	1216	1194			
610	600			730*	710*	Z 23	597	575	Z 48	1237	1215			
				770*	750*	Z 24	622	600	Z 48 1/2	1247	1225			
				795*	775*	Z 25	652	630	Z 49	1272	1250			
				820*	800*	Z 26	672	650	Z 50	1292	1270			
				845	825	Z 27	692	670	Z 51	1317	1295			
				870	850	Z 27 1/2	722	700	Z 52	1342	1320			
				895	875	Z 28	732	710	Z 53	1368	1346			
				920	900	Z 28 1/2	747	725	Z 54	1393	1371			
				970	950	Z 29	752	730	Z 55	1422	1400			
				1020	1000	Z 29 1/2	772	750	Z 56	1444	1422			
				1040	1020	Z 30	787	765	Z 57	1472	1450			
				1070	1050	Z 31	797	775	Z 58	1497	1475			
				1095	1075	Z 31 1/2	822	800	Z 59	1522	1500			
				1140	1120	Z 32	842	820	Z 60	1546	1524			
				1220	1200	Z 33	847	825	Z 61	1572	1550			
				1270	1250	Z 33 1/2	872	850	Z 62	1597	1575			
						Z 34	887	865	Z 63	1622	1600			
						Z 35	897	875	Z 64	1648	1626			
						Z 36	922	900	Z 65	1673	1651			
						Z 37	947	925	Z 66	1697	1675			
						Z 38	972	950	Z 67	1722	1700			

Further sizes on request
Weight:
≈ 0.018 kg/m

Further sizes on request
Weight:
≈ 0.026 kg/m

Maximum production length: 4500 mm
Minimum order quantity:
Over 1800 mm =
20 pieces for non-standard length ranges
60 pieces for special constructions
Weight: ≈ 0.064 kg/m

Datum length L_d ± Pitch length L_w/L_p * Raw edge, cogged V-belts Further sizes on request

STANDARD RANGE
optibelt **VB CLASSIC V-BELTS**
DIN 2215 / ISO 4184

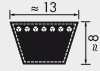

A/13

Profile A/13

Belt no.	Datum length ISO L _d [mm]	Inside length L _i [mm]	Belt no.	Datum length ISO L _d [mm]	Inside length L _i [mm]	Belt no.	Datum length ISO L _d [mm]	Inside length L _i [mm]	Belt no.	Datum length ISO L _d [mm]	Inside length L _i [mm]
A 16	437	407	A 41	1071	1041	A 69	1780	1750	A 105	2697	2667
A 18	487	457	A 41½	1080	1050	A 70	1805	1775	A 107	2755	2725
A 19	510	480	A 42	1090	1060	A 71	1830	1800	A 108	2773	2743
A 20	538	508	A 42½	1105	1075	A 72	1855	1825	A 110	2830	2800
A 21	565	535	A 43	1130	1100	A 73	1884	1854	A 112	2875	2845
A 22	590	560	A 43½	1135	1105	A 74	1910	1880	A 114	2926	2896
A 23	605	575	A 44	1150	1120	A 75	1930	1900	A 116	2976	2946
A 23½	630	600	A 45	1173	1143	A 76	1960	1930	A 118	3030	3000
A 24	640	610	A 45½	1180	1150	A 77	1986	1956	A 120	3078	3048
A 25	660	630	A 46	1198	1168	A 78	2010	1980	A 124	3180	3150
A 26	680	650	A 46½	1210	1180	A 79	2030	2000	A 128	3280	3250
A 26½	700	670	A 47	1230	1200	A 80	2062	2032	A 132	3380	3350
A 27	716	686	A 47½	1245	1215	A 81	2090	2060	A 136	3484	3454
A 27½	730	700	A 48	1250	1220	A 82	2113	2083	A 140	3580	3550
A 28	740	710	A 48½	1255	1225	A 83	2130	2100	A 144	3688	3658
A 29	760	730	A 49	1280	1250	A 83½	2150	2120	A 148	3780	3750
A 29½	780	750	A 50	1300	1270	A 84	2164	2134	A 158	4030	4000
A 30	797	767	A 51	1330	1300	A 84½	2180	2150	A 167	4280	4250
A 31	805	775	A 52	1350	1320	A 85	2190	2160	A 187	4780	4750
A 31½	830	800	A 53	1380	1350	A 86½	2230	2200	A 197	5030	5000
A 32	843	813	A 54	1405	1375	A 87	2240	2210			
A 32½	855	825	A 55	1430	1400	A 88	2270	2240			
A 33	871	841	A 56	1452	1422	A 89	2291	2261			
A 34	880	850	A 57	1480	1450	A 90	2316	2286			
A 34½	905	875	A 58	1505	1475	A 91	2341	2311			
A 35	919	889	A 59	1530	1500	A 92	2367	2337			
A 35½	930	900	A 60	1555	1525	A 93	2390	2360			
A 36	944	914	A 61	1580	1550	A 94	2418	2388			
A 37	955	925	A 62	1605	1575	A 95	2443	2413			
A 37½	980	950	A 63	1630	1600	A 96	2468	2438			
A 38	995	965	A 64	1655	1625	A 97	2494	2464			
A 38½	1005	975	A 65	1680	1650	A 98	2530	2500			
A 39	1030	1000	A 66	1706	1676	A 100	2570	2540			
A 40	1046	1016	A 67	1730	1700	A 102	2621	2591			
A 40½	1060	1030	A 68	1755	1725	A 104	2680	2650			

Maximum production length: 10 000 mm L_i
Minimum order quantity:
Over 1800 mm =
31 pieces for non-standard length ranges
93 pieces for special constructions
Weight: ≈ 0.109 kg/m

Datum length L_d ± Pitch length L_w/L_p Further sizes on request

Lengths in **bold** type are in S=C Plus (Set/Constant).

STANDARD RANGE
optibelt **VB CLASSIC V-BELTS**
DIN 2215 / ISO 4184



B/17

Profile B/17

Belt no.	Datum length ISO L _d [mm]	Inside length L _i [mm]	Belt no.	Datum length ISO L _d [mm]	Inside length L _i [mm]	Belt no.	Datum length ISO L _d [mm]	Inside length L _i [mm]	Belt no.	Datum length ISO L _d [mm]	Inside length L _i [mm]
B 23	610	570	B 51	1340	1300	B 87	2250	2210	B 140	3590	3550
B 24	655	615	B 52	1360	1320	B 88	2280	2240	B 142	3640	3600
B 25	670	630	B 52½	1375	1335	B 89	2301	2261	B 144	3698	3658
B 26	690	650	B 53	1390	1350	B 90	2326	2286	B 146	3740	3700
B 26½	710	670	B 53½	1400	1360	B 91	2340	2300	B 148	3790	3750
B 27	726	686	B 54	1412	1372	B 92	2377	2337	B 150	3850	3810
B 28	750	710	B 55	1440	1400	B 93	2400	2360	B 151	3890	3850
B 29	765	725	B 56	1462	1422	B 94	2428	2388	B 152	3901	3861
B 30	790	750	B 57	1490	1450	B 94½	2440	2400	B 154	3952	3912
B 31	815	775	B 58	1513	1473	B 95	2453	2413	B 155	3990	3950
B 32	840	800	B 59	1540	1500	B 96	2478	2438	B 156	4002	3962
B 32½	865	825	B 60	1565	1525	B 96½	2490	2450	B 158	4040	4000
B 33	876	836	B 61	1590	1550	B 97	2505	2465	B 160	4104	4064
B 34	890	850	B 62	1615	1575	B 98	2540	2500	B 162	4155	4115
B 34½	915	875	B 63	1640	1600	B 99	2555	2515	B 165	4240	4200
B 35	929	889	B 64	1665	1625	B 100	2580	2540	B 167	4290	4250
B 36	940	900	B 65	1690	1650	B 101	2605	2565	B 173	4434	4394
B 37	965	925	B 66	1716	1676	B 102	2640	2600	B 175	4490	4450
B 37½	990	950	B 67	1740	1700	B 103	2656	2616	B 177	4540	4500
B 38	1005	965	B 68	1765	1725	B 104	2690	2650	B 180	4612	4572
B 38½	1015	975	B 69	1790	1750	B 105	2707	2667	B 187	4790	4750
B 39	1040	1000	B 69½	1801	1761	B 106	2740	2700	B 195	4993	4953
B 40	1056	1016	B 70	1815	1775	B 107	2758	2718	B 197	5040	5000
B 40½	1070	1030	B 71	1840	1800	B 108	2790	2750	B 208	5340	5300
B 41	1080	1040	B 72	1869	1829	B 110	2840	2800	B 210	5374	5334
B 41½	1090	1050	B 73	1890	1850	B 112	2885	2845	B 220	5640	5600
B 42	1100	1060	B 74	1920	1880	B 114	2940	2900	B 236	6040	6000
B 42½	1115	1075	B 75	1940	1900	B 115	2961	2921	B 240	6136	6096
B 43	1130	1090	B 76	1970	1930	B 116	2990	2950	B 248	6340	6300
B 43½	1140	1100	B 77	1990	1950	B 118	3040	3000	B 264	6740	6700
B 44	1160	1120	B 78	2021	1981	B 120	3088	3048	B 276	7040	7000
B 45	1190	1150	B 79	2040	2000	B 122	3139	3099	B 280	7140	7100
B 45½	1203	1163	B 80	2072	2032	B 124	3190	3150			
B 46	1215	1175	B 81	2100	2060	B 126	3240	3200			
B 46½	1220	1180	B 82	2123	2083	B 128	3290	3250			
B 47	1240	1200	B 83	2140	2100	B 130	3342	3302			
B 48	1255	1215	B 83½	2160	2120	B 132	3390	3350			
B 48½	1265	1225	B 84	2174	2134	B 134	3444	3404			
B 49	1290	1250	B 85	2200	2160	B 136	3490	3450			
B 50	1315	1275	B 86	2240	2200	B 138	3545	3505			

Maximum production length: 21 000 mm L_i
Minimum order quantity:
Over 1800 mm =
21 pieces for non-standard length ranges
63 pieces for special constructions
Weight: ≈ 0.196 kg/m

Datum length L_d ± Pitch length L_w/L_p Further sizes on request

Lengths in **bold** type are in S=C Plus (Set/Constant).

STANDARD RANGE
optibelt VB CLASSIC V-BELTS
DIN 2215 / ISO 4184

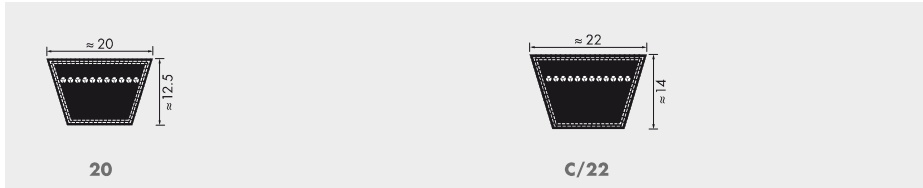

Profile 20			Profile C/22							
Datum length ISO L _d [mm]	Inside length L _i [mm]	Belt no.	Datum length ISO L _d [mm]	Inside length L _i [mm]	Belt no.	Datum length ISO L _d [mm]	Inside length L _i [mm]	Belt no.	Datum length ISO L _d [mm]	Inside length L _i [mm]
950	900	C 43	1148	1090	C 84	2192	2134	C 134	3462	3404
1050	1000	C 47	1258	1200	C 85	2217	2159	C 136	3508	3450
1170	1120	C 48	1273	1215	C 86	2242	2184	C 138	3563	3505
1230	1180	C 49	1308	1250	C 87	2268	2210	C 140	3608	3550
1300	1250	C 51	1353	1295	C 88	2298	2240	C 142	3665	3607
1370	1320	C 52	1378	1320	C 89	2319	2261	C 144	3716	3658
1450	1400	C 53	1408	1350	C 90	2344	2286	C 146	3758	3700
1550	1500	C 54	1433	1375	C 92	2395	2337	C 148	3808	3750
1650	1600	C 55	1458	1400	C 93	2418	2360	C 150	3868	3810
1750	1700	C 56	1483	1425	C 94	2446	2388	C 158	4058	4000
1850	1800	C 57	1508	1450	C 95	2471	2413	C 162	4158	4100
1950	1900	C 58	1533	1475	C 96	2496	2438	C 166	4274	4216
2050	2000	C 59	1558	1500	C 96/2	2508	2450	C 167	4308	4250
2170	2120	C 60	1582	1524	C 97	2522	2464	C 168	4325	4267
2290	2240	C 61	1608	1550	C 98	2558	2500	C 170	4376	4318
2410	2360	C 62	1632	1574	C 99	2583	2525	C 173	4452	4394
2550	2500	C 63	1658	1600	C 100	2598	2540	C 175	4503	4445
2700	2650	C 65	1708	1650	C 101	2618	2560	C 177	4558	4500
2850	2800	C 66	1734	1676	C 102	2649	2591	C 180	4630	4572
3050	3000	C 67	1758	1700	C 104	2700	2642	C 187	4808	4750
3200	3150	C 68	1785	1727	C 105	2725	2667	C 190	4884	4826
3400	3350	C 69	1808	1750	C 106	2750	2692	C 195	5011	4953
3600	3550	C 70	1836	1778	C 108	2808	2750	C 197	5058	5000
3800	3750	C 71	1858	1800	C 110	2858	2800	C 208	5358	5300
4050	4000	C 72	1887	1829	C 112	2903	2845	C 210	5392	5334
4550	4500	C 73	1912	1854	C 114	2954	2896	C 220	5658	5600
5050	5000	C 74	1938	1880	C 115	2979	2921	C 225	5773	5715
6050	6000	C 75	1958	1900	C 116	3008	2950	C 236	6058	6000
		C 76	1988	1930	C 117	3023	2965	C 240	6154	6096
		C 77	2014	1956	C 118	3058	3000	C 248	6358	6300
		C 78	2039	1981	C 120	3106	3048	C 264	6758	6700
		C 79	2058	2000	C 122	3157	3099	C 270	6916	6858
		C 80	2090	2032	C 124	3208	3150	C 280	7158	7100
		C 81	2118	2060	C 126	3258	3200	C 295	7558	7500
		C 82	2141	2083	C 128	3308	3250	C 300	7678	7620
		C 83	2166	2108	C 130	3360	3302	C 315	8058	8000
		C 83 1/2	2178	2120	C 132	3408	3350			

Maximum production length:
10 000 mm L_i
Minimum order quantity:
Over 1800 mm =
18 pieces for non-standard
length ranges
54 pieces for special
constructions
Weight: ≈ 0.266 kg/m

Maximum standard production length: 21 000 mm L_i
Over 18 000 to 21 000 mm on request
Minimum order quantity:
Over 1800 mm =
16 pieces for non-standard length ranges
48 pieces for special constructions
Weight: ≈ 0.324 kg/m

Datum length L_d ± Pitch length L_w/L_p Further sizes on request

Lengths in **bold** type are in S=C Plus (Set/Constant).

STANDARD RANGE
optibelt VB CLASSIC V-BELTS
DIN 2215 / ISO 4184

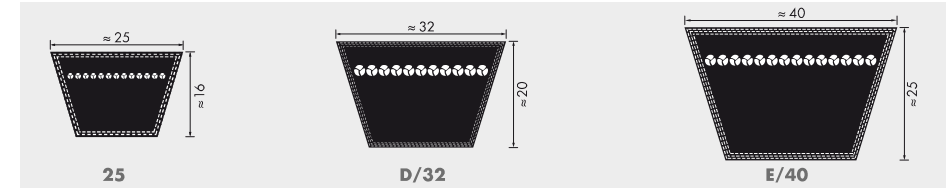

Profile 25		Profile D/32			Profile E/40		
Datum length ISO L _d [mm]	Inside length L _i [mm]	Belt no.	Datum length ISO L _d [mm]	Inside length L _i [mm]	Belt no.	Datum length ISO L _d [mm]	Inside length L _i [mm]
1460	1400	D 79	2075	2000	E 118	3080	3000
1560	1500	D 98	2575	2500	E 158	4080	4000
1660	1600	D 104	2725	2650	E 197	5080	5000
1760	1700	D 110	2875	2800	E 220	5680	5600
1860	1800	D 118	3075	3000	E 236	6080	6000
1960	1900	D 120	3123	3048	E 248	6380	6300
2060	2000	D 124	3225	3150	E 280	7180	7100
2180	2120	D 128	3326	3251	E 295	7580	7500
2300	2240	D 132	3425	3350	E 315	8080	8000
2420	2360	D 135	3500	3425	E 354	9080	9000
2560	2500	D 136	3529	3454	E 394	10080	10000
2710	2650	D 140	3625	3550	E 441	11280	11200
2760	2700	D 144	3733	3658	E 492	12580	12500
2860	2800	D 148	3825	3750			
3060	3000	D 154	4000	3925			
3210	3150	D 158	4075	4000			
3410	3350	D 162	4190	4115			
3610	3550	D 167	4325	4250			
3810	3750	D 173	4469	4394			
4060	4000	D 177	4575	4500			
4310	4250	D 180	4647	4572			
4560	4500	D 187	4825	4750			
4810	4750	D 195	5028	4953			
5060	5000	D 197	5075	5000			
5360	5300	D 208	5375	5300			
5660	5600	D 210	5409	5334			
6060	6000	D 220	5675	5600			
6360	6300	D 225	5790	5715			
6760	6700	D 236	6075	6000			
7160	7100	D 240	6171	6096			
7560	7500	D 248	6375	6300			
8060	8000	D 264	6775	6700			
8560	8500	D 270	6933	6858			
9060	9000	D 280	7175	7100			
		D 295	7575	7500			
		D 300	7695	7620			
		D 315	8075	8000			
		D 330	8457	8382			
		D 335	8575	8500			
		D 354	9075	9000			
		D 374	9575	9500			
		D 394	10075	10000			
		D 441	11275	11200			

Maximum standard production length:
21 000 mm L_i
Over 18 000 to 21 000 mm on request
Minimum order quantity:
Over 1800 mm =
14 pieces for non-standard length ranges
42 pieces for certain special constructions
Weight: ≈ 0.420 kg/m

Maximum standard production length: 21 000 mm L_i
Over 18 000 to 21 000 mm on request
Minimum order quantity:
Over 2000 mm =
11 pieces for non-standard length ranges
33 pieces for certain special constructions
Weight: ≈ 0.668 kg/m

Maximum production length: 21 000 mm L_i
Minimum order quantity:
Over 3000 mm =
7 pieces for non-standard length ranges
21 pieces for certain special constructions
Weight: ≈ 0.958 kg/m

Datum length L_d ± Pitch length L_w/L_p Further sizes on request

Lengths in **bold** type are in S=C Plus (Set/Constant).