

GEARex® FA, FB und FAB Ganzstahlzahnkupplungen

Kupplung gemäß AGMA 9008-B00, hohe Leistungsdichte

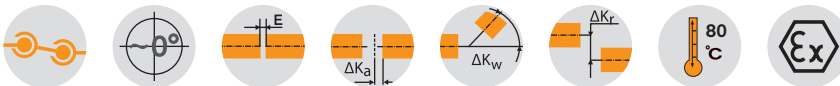

Piktogrammlegende ist auf dem Klapper am Umschlag zu finden



Abmessungen																		
Größe	Vorbohrung	max. Fertigbohrung d ₁ ; d ₂	Abmessungen [mm]															Fettfüllung [dm ³] ²⁾
			l ₁ , l ₂	Nabe verlängert max l ₁ , l ₂	EFA	EFB	EFAB	LFA	LFB	LFAB	L ₃	D	DA ₁	DA ₂	F ¹⁾	d ₃ ¹⁾		
10	26	50	43	105	3	21	12	89	107	98	55	67	111	84	74	52	0,02	
15	26	64	50	115	3	15	9	103	115	109	59	87	152	107	84	68	0,04	
20	31	80	62	130	3	31	17	127	155	141	79	108	178	130	104	85	0,08	
25	38	98	76	150	5	29	17	157	181	169	93	130	213	158	123	110	0,12	
30	44,5	112	90	170	5	33	19	185	213	199	109	153	240	182	148	130	0,18	
35	46	133	105	185	6	40	23	216	250	233	128	180	280	214	172	150	0,22	
40	52	158	120	215	6	42	24	246	282	264	144	214	318	250	192	175	0,35	
45	80	172	135	245	8	50	29	278	320	299	164	233	347	274	216	190	0,45	
50	80	192	150	295	8	56	32	308	356	332	182	260	390	309	241	220	0,70	
55	90	210	175	300	8	70	39	358	420	389	214	283	425,5	334	275	250	0,90	
60	100	232	190	305	8	84	46	388	464	426	236	312	457	365,5	316	265	1,15	
70	100	276	220	310	10	76	43	450	516	483	263	371	527	425	360	300	1,50	

Technische Daten										
Größe	Drehmoment [Nm]		max. Drehzahl [1/min]	Gewicht bei max. Bohrung [kg]			Massenträgheitsmoment bei max. Bohrung [kgm ²]	Passschraube (10.9)		
	T _{KN}	T _{KN} (42CrMo4)		Hülse	Nabe	Gesamt		z	M	T _A [Nm]
10	930	1580	8500	0,75	0,55	2,73	0,00436	6	M6	15
15	2000	3300	7700	1,88	1,12	6,38	0,01894	8	M8	36
20	3500	6300	6900	2,60	2,09	9,94	0,04000	6	M10	72
25	6500	11000	6200	4,43	3,56	16,83	0,09749	6	M12	125
30	10000	17400	5800	5,83	6,18	25,21	0,18080	8	M12	125
35	17000	28800	5100	9,71	9,87	41,25	0,41419	8	M14	200
40	28500	48500	4500	11,88	16,07	58,14	0,75535	8	M14	200
45	37000	62000	4000	15,72	21,42	77,08	1,17590	10	M14	200
50	51000	86000	3750	25,66	29,59	114,40	2,24991	8	M18	430
55	65000	110000	3550	31,52	40,30	150,41	3,45102	14	M18	430
60	85000	145000	3400	32,82	52,96	177,44	4,16734	14	M18	430
70	135000	240000	3200	43,52	85,77	268,20	9,32429	16	M20	610

■ = Standard

¹⁾ Benötigter Bauraum zum Ausrichten der Kupplung bzw. zum Erneuern des Dichtringes

²⁾ Fettfüllung je Kupplungshälfte

Bestell- beispiel:	GEARex® FA 10	d ₁ Ø50	d ₂ Ø50
	Kupplungsbauart/-größe	Fertigbohrung mit Nute DIN 6885 Bl. 1	Fertigbohrung mit Nute DIN 6885 Bl. 1

Bauart FA

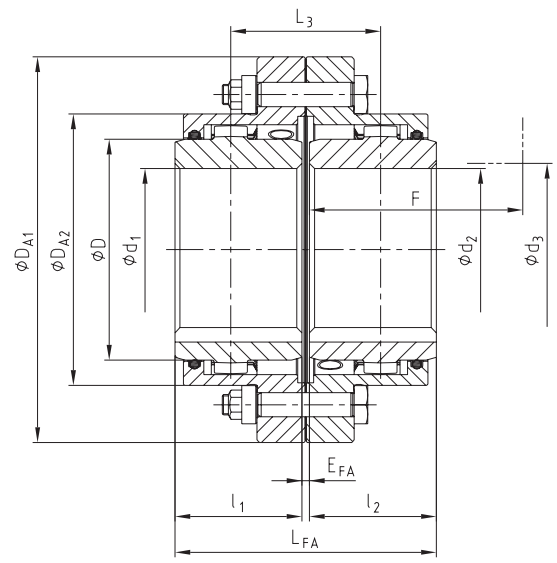

Bauart FB

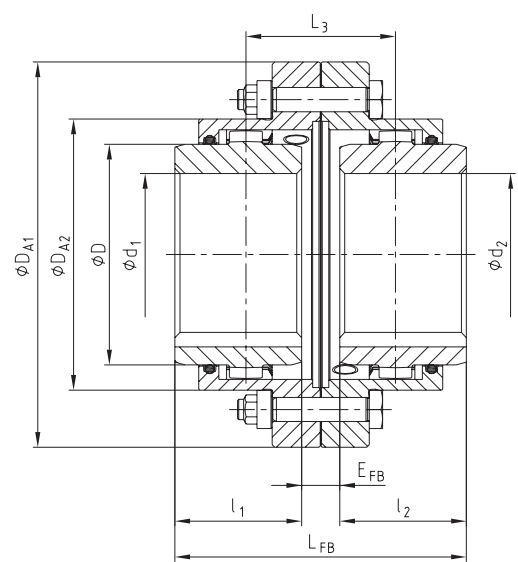

Bauart FAB

