

ROFLEX® SH elastische Klauenkupplungen

Kupplung mit SPLIT-Nabe

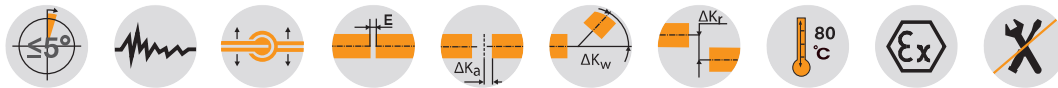

Bauteile

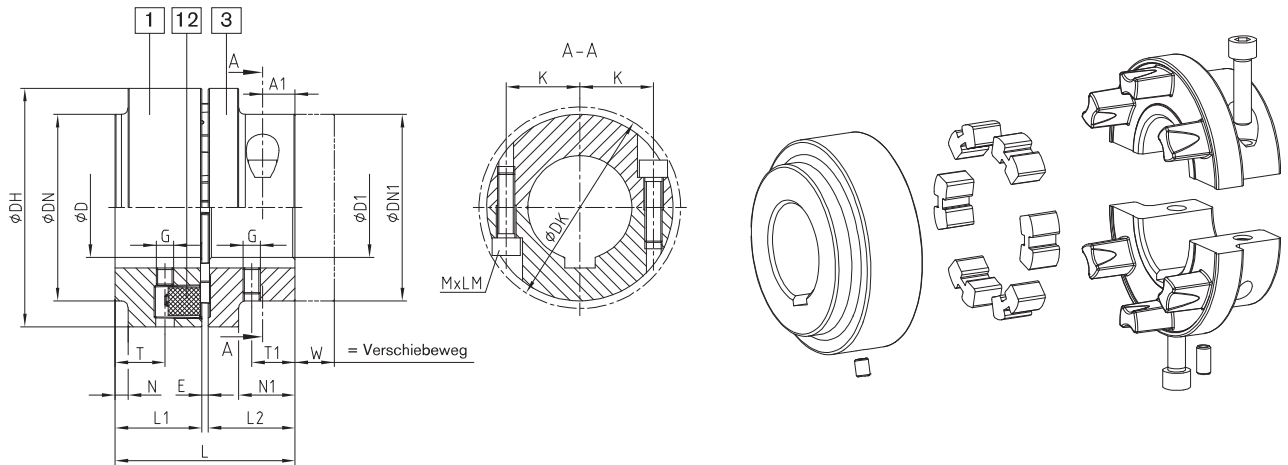

ROFLEX® Bauart SH																												
Größe	Drehmoment		max. Drehzahl [1/min]	Abmessungen														Massenträgheitsmoment J1 [kgm²] 1)	Massenträgheitsmoment J3 [kgm²] 1)	Gewicht [kg] 1)								
	TKN [Nm]	TK max [Nm]		Allgemein							Feststellgewinde			Zylinderschrauben														
			D	D1	L	L1	L2	E	DH	DN	DN1	N	N1	W	G	T	T1	TA [Nm]	MxLM	DK	K	A1	A2	TA [Nm]				
80	80	220	7500	35	38	63	30	30	3	80	80	68	-	20	15,5	M8	20,5	12	10	M8x25	75	25	11	-	34	0,00059	0,00058	1,3
95	125	345	6800	45	42	73	35	35	3	95	76	76	5	23	18	M8	22	15	10	M8x30	82	28,5	13	-	34	0,00116	0,00123	2,0
110	205	565	6500	50	48	83	40	40	3	110	86	86	6	26	21	M8	24	18	10	M8x35	94	31,5	15	-	34	0,0024	0,0025	3,1
125	315	865	5800	60	55	103	50	50	3	125	100	100	14	32	23,5	M8	32	20	10	M10x40	108	38,5	20	-	67	0,0046	0,0052	4,5
140	450	1240	5400	70	60	113	55	55	3	140	100	100	21	35	25	M10	13	22	17	M10x35	108	39,0	10,5	25,5	67	0,0062	0,0080	5,7
160	790	2170	4800	75	65	124	60	60	4	160	108	108	21	40	30	M10	13	25	17	M12x35	118	42,5	12	29	115	0,014	0,014	8,5
180	1150	3160	4350	85	75	144	70	70	4	180	125	125	28	50	32	M10	16	32	17	M12x40	135	50	15	35	115	0,021	0,024	11,6
200	1800	4950	3950	90	85	164	80	80	4	200	140	140	33	56	34	M12	20	40	40	M16x50	153	54	17	40	290	0,038	0,044	17,8
225	2100	5775	3600	100	90	184,0	90	90	4,0	225	150	150	38	73	39,0	M12	22	40	40	M20x50	170	58	22	30	560	0,06	0,06	20,4
250	3550	9765	3000	110	100	205,5	100	100	5,5	250	165	165	40	82	44,5	M16	24	40	80	M20x55	182	63	25	35	560	0,11	0,1	28,2
280	5000	13750	3000	120	120	225,5	110	110	5,5	280	180	180	45	90	50,0	M16	28	45	80	M16x60	194	72	17	29	290	0,19	0,16	38,1

1) Massenträgheitsmomente J1 und J3 sowie das Gesamtgewicht beziehen sich auf die maximalen Bohrungsdurchmesser

Bestell- beispiel:	ROFLEX® 110	SH	ØD = 42	ØD1 = 48
	Kupplungsgröße	Bauart	Fertigbohrung	Fertigbohrung