

Synchronscheiben AT-Profil

AT 20 (Auch für ATN-Zahnriemen)

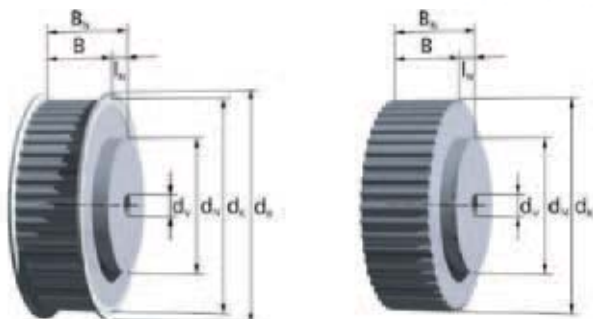

Beispiel für Bestellbezeichnung:

Synchronscheibe AL 70 AT 20 / 60 - 0 Nabe 140x10; dv
 Werkstoff _____
 Gesamtbreite B_N _____
 Typ / Teilung _____
 Zähnezahl _____
 Anzahl Bordscheiben _____
 Nabenabmessung $d_N \times l_N$ _____

Anmerkung zur Bestellbezeichnung:

dv = Durchmesser vorgebohrt.

Weitere Bestellhinweise auf Seite 14ff.

Riemenbreite	b [mm]	32	50	75	100
Synchronscheibenbreite	B [mm]	40	60	85	110
Breite für ATN-Systeme	B [mm]	-	60	85	110
Gesamtbreite	B_N [mm]	50	70	95	120

Werkstoffe:	
Synchronscheibe:	AlCu4MgSi, RoHS-konform
Bordscheibe:	Stahl, verzinkt, geschraubt

Zwischen- und größere Breiten möglich (nicht bei ATN-Zahnriemen).

Andere Nabenabmessungen möglich.

- z = Zähnezahl
- d_k = Kopfkreisdurchmesser
- d_o = Wirkkreisdurchmesser
- d_B = Bordscheibendurchmesser
- d_N = Nabendurchmesser

- l_N = Nabenlänge
- d_v = Durchmesser der Vorbohrung
- d_{max} = max. Bohrungsdurchmesser ohne Passfedernut für Synchronscheiben mit Bordscheiben, Nabe entfällt bei maximaler Vorbohrung

z	Nabe			Bohrung		
	d_k [mm]	d_o [mm]	d_B [mm]	$d_N \times l_N$ [mm]	d_v [mm]	d_{max} [mm]
18	111,77	114,59	121	70x10	12H7	86
19	118,14	120,96	128	80x10	12H7	93
20	124,50	127,32	134	90x10	16H7	100
21	130,87	133,69	140	90x10	16H7	105
22	137,24	140,06	147	90x10	16H7	112
23	143,60	146,42	153	90x10	16H7	118
24	149,97	152,79	160	95x10	16H7	125
25	156,33	159,15	166	95x10	16H7	131
26	162,70	165,52	172	95x10	16H7	137
27	169,07	171,89	179	110x10	16H7	144
28	175,43	178,25	185	110x10	16H7	150
29	181,80	184,62	192	110x10	16H7	156

z	Nabe			Bohrung		
	d_k [mm]	d_o [mm]	d_B [mm]	$d_N \times l_N$ [mm]	d_v [mm]	d_{max} [mm]
30	188,17	190,99	198	110x10	16H7	163
31	194,53	197,35	204	110x10	16H7	169
32	200,90	203,72	210	110x10	16H7	175
33	207,26	210,08	217	110x10	16H7	182
34	213,63	216,45	223	110x10	16H7	188
35	220,00	222,82	229	110x10	16H7	195
36	226,36	229,18	236	110x10	18H7	201
37	232,73	235,55	242	110x10	18H7	207
38	239,10	241,92	249	110x10	18H7	214
39	245,46	248,28	255	110x10	18H7	220
40	251,83	254,65	261	110x10	18H7	226
41	258,19	261,01	268	130x10	18H7	233
42	264,56	267,38	274	130x10	18H7	239
43	270,93	273,75	280	130x10	18H7	245
44	277,29	280,11	287	130x10	18H7	252

AT 20 (Auch für ATN-Zahnriemen)

z	Nabe			Bohrung		
	d _K [mm]	d ₀ [mm]	d _B [mm]	d _N x l _N [mm]	d _V [mm]	d _{max} [mm]
45	283,66	286,48	293	130x10	18H7	258
46	290,03	292,85	300	130x10	18H7	265
47	296,39	299,21	306	130x10	18H7	271
48	302,76	305,58	312	130x10	18H7	278
49	309,12	311,94	319	140x10	20H7	284
50	315,49	318,31	325	140x10	20H7	290
51	322,86	324,68	331	140x10	20H7	296
52	328,22	331,04	338	140x10	20H7	303
53	334,59	337,41	344	140x10	20H7	310
54	340,95	343,77	350	140x10	20H7	315
55	347,32	350,14	357	140x10	20H7	322
56	353,69	356,51	363	140x10	20H7	328
57	360,05	362,87	370	140x10	20H7	335
58	366,42	369,24	376	140x10	20H7	341
59	372,79	375,61	382	140x10	20H7	347
60	379,15	381,97	389	140x10	20H7	354
61	385,52	388,34	395	140x10	20H7	360
62	391,88	394,70	401	140x10	20H7	366
63	398,25	401,07	408	140x10	20H7	373
64	404,62	407,44	414	140x10	20H7	379
65	410,98	413,80	420	140x10	20H7	385
66	417,35	420,17	427	140x10	20H7	392
67	423,72	426,54	433	140x10	20H7	398
68	430,08	432,90	440	140x10	20H7	405
69	436,45	439,27	446	140x10	20H7	406
70	442,81	445,63	452	140x10	20H7	412
71	449,18	452,00	459	140x10	20H7	419
72	455,55	458,37	465	140x10	20H7	425
73	461,91	464,73	471	160x10	30H7	431
74	468,28	471,10	478	160x10	30H7	438
75	474,64	477,46	484	160x10	30H7	444
76	481,01	483,83	490	160x10	30H7	450
77	487,38	490,20	497	160x10	30H7	457
78	493,74	496,56	503	160x10	30H7	463
79	500,11	502,93	510	160x10	30H7	470

z	Nabe			Bohrung		
	d _K [mm]	d ₀ [mm]	d _B [mm]	d _N x l _N [mm]	d _V [mm]	d _{max} [mm]
80	506,48	509,30	516	200x10	30H7	476
81	512,84	515,66	522	200x10	30H7	482
82	519,21	522,03	529	200x10	30H7	489
83	525,57	528,39	535	200x10	30H7	495
84	531,94	534,76	541	200x10	30H7	501
85	538,31	541,13	548	200x10	30H7	503
86	544,67	547,49	554	200x10	30H7	509
87	551,04	553,86	561	200x10	30H7	516
88	557,41	560,23	567	200x10	30H7	522
89	563,77	566,59	573	200x10	30H7	528
90	570,14	572,96	580	200x10	30H7	535
91	576,50	579,32	586	200x10	30H7	541
92	582,87	585,69	592	200x10	30H7	548
93	589,24	592,06	599	200x10	30H7	554
94	595,60	598,42	605	200x10	30H7	560
95	601,97	604,79	611	200x10	40H7	566
96	608,33	611,15	618	200x10	40H7	573
97	614,70	617,52	624	200x10	40H7	579
98	621,07	623,89	631	200x10	40H7	586
99	627,43	630,25	637	200x10	40H7	592
100	633,80	636,62	643	200x10	40H7	598
101	640,17	642,99	650	200x10	40H7	605
102	646,53	649,35	656	200x10	40H7	611
103	652,90	655,72	662	200x10	40H7	617
104	659,26	662,08	669	200x10	40H7	624
105	665,63	668,45	675	200x10	40H7	630
106	672,00	674,82	681	200x10	40H7	636
107	678,36	681,18	688	200x10	40H7	643
108	684,73	687,55	694	200x10	40H7	649
109	691,10	693,92	701	200x10	40H7	656
110	697,46	700,28	707	200x10	40H7	662
111	703,83	706,65	713	200x10	40H7	663
112	710,19	713,01	720	200x10	40H7	670
113	716,56	719,38	726	200x10	40H7	676
114	722,93	725,75	732	200x10	40H7	682