

z	d <sub>k</sub> [mm]	d <sub>0</sub> [mm]	d <sub>B</sub> [mm]	Nabe d <sub>N</sub> xl <sub>N</sub> [mm]	Gesamtbreite B <sub>N</sub> (F) [mm]	verzahnte Breite B (L) [mm]	Vorbereitung d <sub>v</sub>
32	49,79	50,93	55	38x7,5	28	20,5	6
36	56,16	57,30	61	38x7,5	28	20,5	8
40	62,52	63,66	68	38x7,5	28	20,5	8
44	68,89	70,03	74	38x9,5	30	20,5	8
48	75,25	76,39	80	45x9,5	30	20,5	8
60	94,35	95,49	99	60x9,5	30	20,5	8
72	113,45	114,59	118	80x9,5	30	20,5	8
Riemenbreite b=25 mm							
12	17,96	19,10	23	13x5,5	36	30,5	4
14	21,14	22,28	26	13x5,5	36	30,5	6
15	22,73	23,87	28	16x5,5	36	30,5	6
16	24,32	25,46	30	16x5,5	36	30,5	6
18	27,51	28,65	34	19x5,5	36	30,5	6
20	30,69	31,83	36	23x5,5	36	30,5	6
22	33,87	35,01	39	25x7,5	38	30,5	6
24	37,06	38,20	42	27x7,5	38	30,5	6
26	40,24	41,38	45	30x7,5	38	30,5	6
28	43,42	44,56	48	30x7,5	38	30,5	6
30	46,60	47,75	52	35x7,5	38	30,5	6
32	49,79	50,93	55	38x7,5	38	30,5	6
36	56,16	57,30	61	38x7,5	38	30,5	8
40	62,52	63,66	68	38x7,5	38	30,5	8
44	68,89	70,03	74	38x9,5	40	30,5	8
48	75,25	76,39	80	45x9,5	40	30,5	8
60	94,35	95,49	99	60x9,5	40	30,5	8
72	113,45	114,59	118	80x9,5	40	30,5	8

Riemenbreite b=9 mm							
z	d <sub>k</sub> [mm]	d <sub>0</sub> [mm]	d <sub>B</sub> [mm]	Nabe d <sub>N</sub> xl <sub>N</sub> [mm]	Gesamtbreite B <sub>N</sub> (F) [mm]	verzahnte Breite B (L) [mm]	Vorbereitung d <sub>v</sub>
12	17,96	19,10	23	13x5,5	20	14,5	4
14	21,14	22,28	26	13x5,5	20	14,5	6
15	22,73	23,87	28	16x5,5	20	14,5	6
16	24,32	25,46	30	16x5,5	20	14,5	6
18	27,51	28,65	34	19x5,5	20	14,5	6
20	30,69	31,83	36	23x8	22,5	14,5	6
22	33,87	35,01	39	25x8	22,5	14,5	6
24	37,06	38,20	42	27x8	22,5	14,5	6
26	40,24	41,38	45	30x8	22,5	14,5	6
28	43,42	44,56	48	30x8	22,5	14,5	6
30	46,60	47,75	52	35x8	22,5	14,5	6
32	49,79	50,93	55	38x8	22,5	14,5	6
36	56,16	57,30	61	38x8	22,5	14,5	8
40	62,52	63,66	68	38x8	22,5	14,5	8
44	68,89	70,03	74	38x11	25,5	14,5	8
48	75,25	76,39	80	45x11	25,5	14,5	8
60	94,35	95,49	99	60x11	25,5	14,5	8
72	113,45	114,59	118	80x11	25,5	14,5	8
Riemenbreite b=15 mm							
12	17,96	19,10	23	13x5,5	26	20,5	4
14	21,14	22,28	26	13x5,5	26	20,5	6
15	22,73	23,87	28	16x5,5	26	20,5	6
16	24,32	25,46	30	16x5,5	26	20,5	6
18	27,51	28,65	34	19x5,5	26	20,5	6
20	30,69	31,83	36	23x5,5	26	20,5	6
22	33,87	35,01	39	25x5,5	26	20,5	6
24	37,06	38,20	42	27x7,5	28	20,5	6
26	40,24	41,38	45	30x7,5	28	20,5	6
28	43,42	44,56	48	30x7,5	28	20,5	6
30	46,60	47,75	52	35x7,5	28	20,5	6

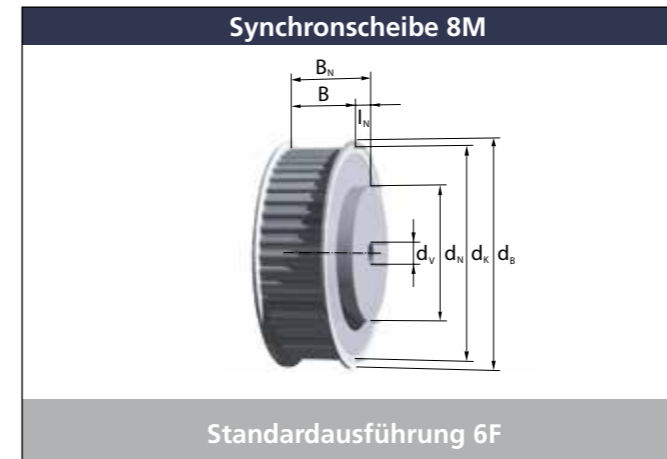
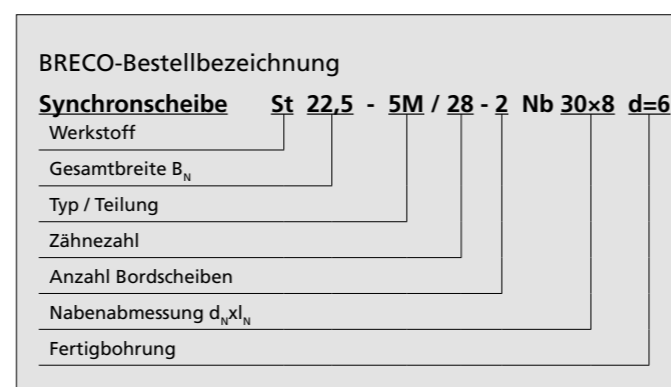
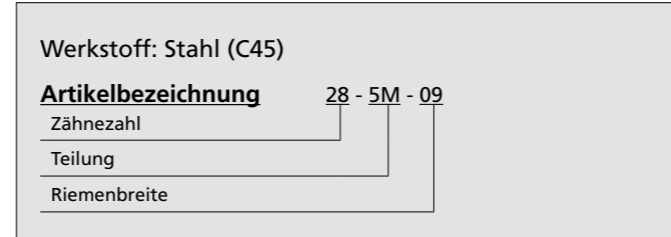

Riemenbreite b=20 mm							
z	d <sub>k</sub> [mm]	d <sub>0</sub> [mm]	d <sub>B</sub> [mm]	Nabe d <sub>N</sub> xl <sub>N</sub> [mm]	Gesamtbreite B <sub>N</sub> (F) [mm]	verzahnte Breite B (L) [mm]	Vorbereitung d <sub>v</sub>
22	54,65	56,02	60	43x10	38	28	12
24	59,75	61,12	66	45x10	38	28	12
26	64,84	66,21	71	50x10	38	28	12
28	70,08	71,30	75	50x10	38	28	15
30	75,13	76,39	83	55x10	38	28	15
32	80,16	81,49	87	60x10	38	28	15
34	85,22	86,58	91	70x10	38	28	15
36	90,30	91,67	98	70x10	38	28	15
38	95,39	96,77	103	75x10	38	28	15
40	100,49	101,86	106	75x10	38	28	15
44	110,67	112,05	119	75x10	38	28	15
48	120,86	122,23	127	75x10	38	28	15
56	141,23	142,60	148	80x10	38	28	15
64	161,6	162,97	168	80x10	38	28	15
72	181,97	183,35	192	80x10	38	28	15
80	202,35	203,72	210	90x10	38	28	15
Riemenbreite b=50 mm							
22	54,65	56,02	60	43x10	70	60	12
24	59,75	61,12	66	45x10	70	60	12
26	64,84	66,21	71	50x10	70	60	12
28	70,08	71,30	75	50x10	70	60	15
30	75,13	76,39	83	55x10	70	60	15
32	80,16	81,49	87	60x10	70	60	15
34	85,22	86,58	91	70x10	70	60	15
36	90,30	91,67	98	70x10	70	60	15
38	95,39	96,77	103	75x10	70	60	15
40	100,49	101,86	106	75x10	70	60	18
44	110,67	112,05	119	80x10	70	60	18
48	120,86	122,23	127	80x10	70	60	18
56	141,23	142,60	148	90x10	70	60	18

z	d <sub>k</sub> [mm]	d <sub>0</sub> [mm]	d <sub>B</sub> [mm]	Nabe d <sub>N</sub> xl <sub>N</sub> [mm]	Gesamtbreite B <sub>N</sub> (F) [mm]	verzahnte Breite B (L) [mm]	Vorbereitung d <sub>v</sub>
64	161,6	162,97	168	100x10	70	60	18
72	181,97	183,35	192	100x10	70	60	18
80	202,35	203,72	210	100x10	70	60	18
Riemenbreite b=85 mm							
22	54,65	56,02	60	43x10	105	95	12
24	59,75	61,12	66	45x10	105	95	12
26	64,84	66,21	71	50x10	105	95	12
28	70,08	71,30	75	50x10	105	95	15
30	75,13	76,39	83	55x10	105	95	15
32	80,16	81,49	87	60x10	105	95	15
34	85,22	86,58	91	70x10	105	95	15
36	90,30	91,67	98	70x10	105	95	15
38	95,39	96,77	103	75x10	105	95	15
40	100,49	101,86	106	75x10	105	95	18
44	110,67	112,05	119	75x10	105	95	18
48	120,86	122,23	127	80x10	105	95	18
56	141,23	142,60	148	90x10	105	95	20
64	161,60	162,97	168	100x10	105	95	20
72	181,97	183,35	192	100x10	105	95	20
80	202,35	203,72	210	110x10	105	95	20

